

Smart Grid Semiconductor Solutions

Adding more than intelligence to the grid





Table of Contents

Executive Summary	04
Three Goals for the Future	05
Smart Grids	08
Power Conversion	10
Advanced Transmission & Distribution	12
Smart City	14
Smart Metering	16
Security	18
Electric Vehicles	20
Public Transportation	22
Smart Lighting	24
Smart Homes	26



Image courtesy of NASA/Goddard Space Flight Center and Scientific Visualization Studio



Image courtesy of NASA/Goddard Space Flight Center and Scientific Visualization Studio

Executive Summary

Electric grids are the largest technical constructions in the world – but years behind compared with the innovations seen in other technical fields. The drive for an environmentally friendly, low-CO₂ world, higher quality requirements of modern industries and the rapid increase in energy consumption in emerging countries raise the need for a new electrical grid system.

The following three goals need to be reached:

- Reducing CO₂ emissions
- Balancing supply and demand of electricity
- Creating grid stability and security

To address all these topics, smart grids are necessary. A smart grid is an upgrade of our existing grids with distributed local intelligence, security, efficiency and upgraded control capabilities. It provides solutions on how to transform our hierarchical grid system into a de-centralized one.

Three Goals for the Future

Smart infrastructures are becoming compelling as people's habits have changed significantly over the last 20 years: More than half of the world's population lives in cities today. The number of cities counting more than 1 million inhabitants almost doubled from 1990 to 2012¹ and is still growing. 20 years ago the average energy consumed in homes was mainly used for "primary needs", such as lighting, heating and cooking, whereas today an increasing amount of energy is consumed by appliances such as multimedia, communication and IT equipment. Those changes require radical rethinking of the way we utilize energy and imply a fast transition to smart cities – where energy for mobility, lighting and for citizens is properly and securely managed – and to smart homes which allow minimizing non necessary power such as power supply losses and standby power, and which enable renewable energies integration and demand/supply balancing.

Many ingredients are needed to enable the transition from the current infrastructure to a "smart" infrastructure: security, to prevent fraud and malicious attacks; intelligent devices, sensors and MCUs, to allow distributed control; efficient power semiconductors, to reduce power losses and offer the reliability needed by a critical service like energy.

Infineon is strongly engaged in the field of energy efficiency with a vast portfolio of semiconductor devices targeted to smart grids, cities and homes. The company has a specific focus on innovation to make sure up-to-date semiconductor products are always available to enable a fast modernization of the energy infrastructure: secure, reliable, efficient, cost-effective and easy-to-deploy ICs and power devices. And as needs and requirements evolve rapidly, Infineon is in the best position to timely serve its customers with the best new technologies and components.

¹ source <http://esa.un.org>



As CO₂ reduction, grid capacity and increasing consumption are major concerns, there is a need to minimize energy losses (including thermal energy, which turns into CO₂ emissions).

Non semiconductor-enabled Smart Grid



This is why renewable energies, efficient transmission and distribution and careful consumption management are the key to ensuring a sustainable and environmentally friendly world growth.

Semiconductor-enabled Smart Grid

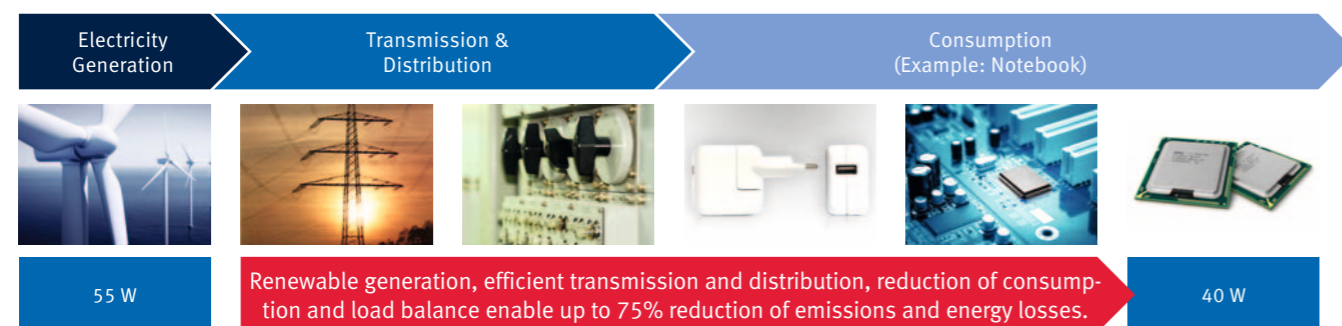

In the Consumption Area, significant Energy Savings are possible today

		Electricity consumption	Saving potential	Application examples
Consumers electrical energy (ww)	Consumer power supply: stand-by, active mode, ...	Others 14%	1% ... >90%	
	Computing power supply: stand-by, active mode	Information & communication 10%	>>1%	
	EC-ballast, daylight dimming, HID, LED, ...	Lighting 21%	>25%	
	Factory automation, process engineering, heavy industry, light industry, ...	Motors 55%	25% ... >40%	
	Transportation: train, bus, car, ...			
	Home appliances: refrigerator, washing machine, air conditioning, ...			

Source: ZVEI, Infineon, 2008

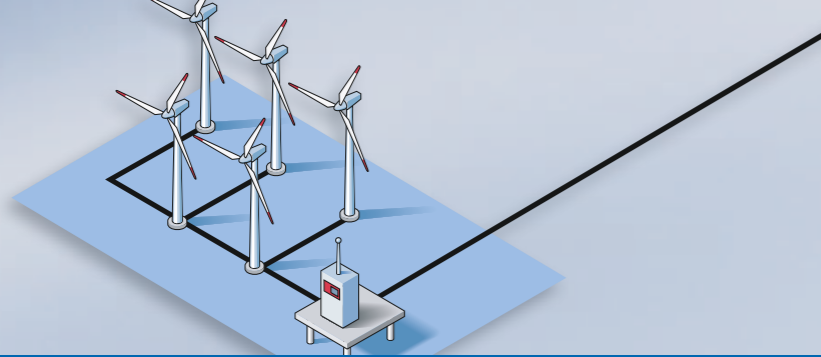

Power Conversion



Advanced Transmission & Distribution



Smart City

Smart Grids

A smart grid is an upgrade of our existing grids towards a stable, clean and secure future. It combines power conversion and advanced transmission & distribution and embeds Smart Cities.

In Smart Cities distributed energy generation and storage, security and efficient consumption are enabled by diffused cyber security, efficient public transportation and lighting, electromobility and smart homes – where smart meters and smart appliances allow easy monitoring and management of energy consumption.



Smart Grids	08
Power Conversion	10
Advanced Transmission & Distribution	12
Smart City	14
Smart Metering	16
Security	18
Electric Vehicles	20
Public Transportation	22
Smart Lighting	24
Smart Homes	26

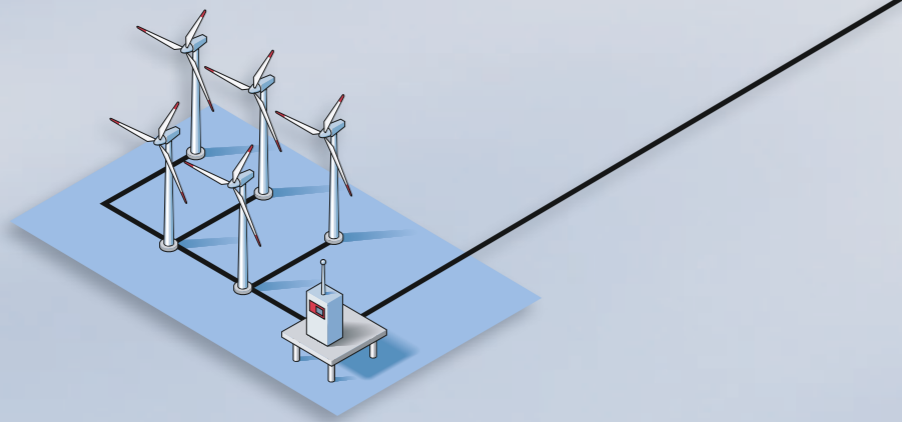

Power Conversion

Infineon provides a comprehensive portfolio of high-power products for Power Conversion, to help its customers to achieve their aims. These high-performance products boost the reliability and efficiency of inverters for photovoltaic or wind applications.

Power electronic converters enable the efficient conversion of variable frequency output from the generator to a fixed frequency appropriate for the grid in the region concerned.

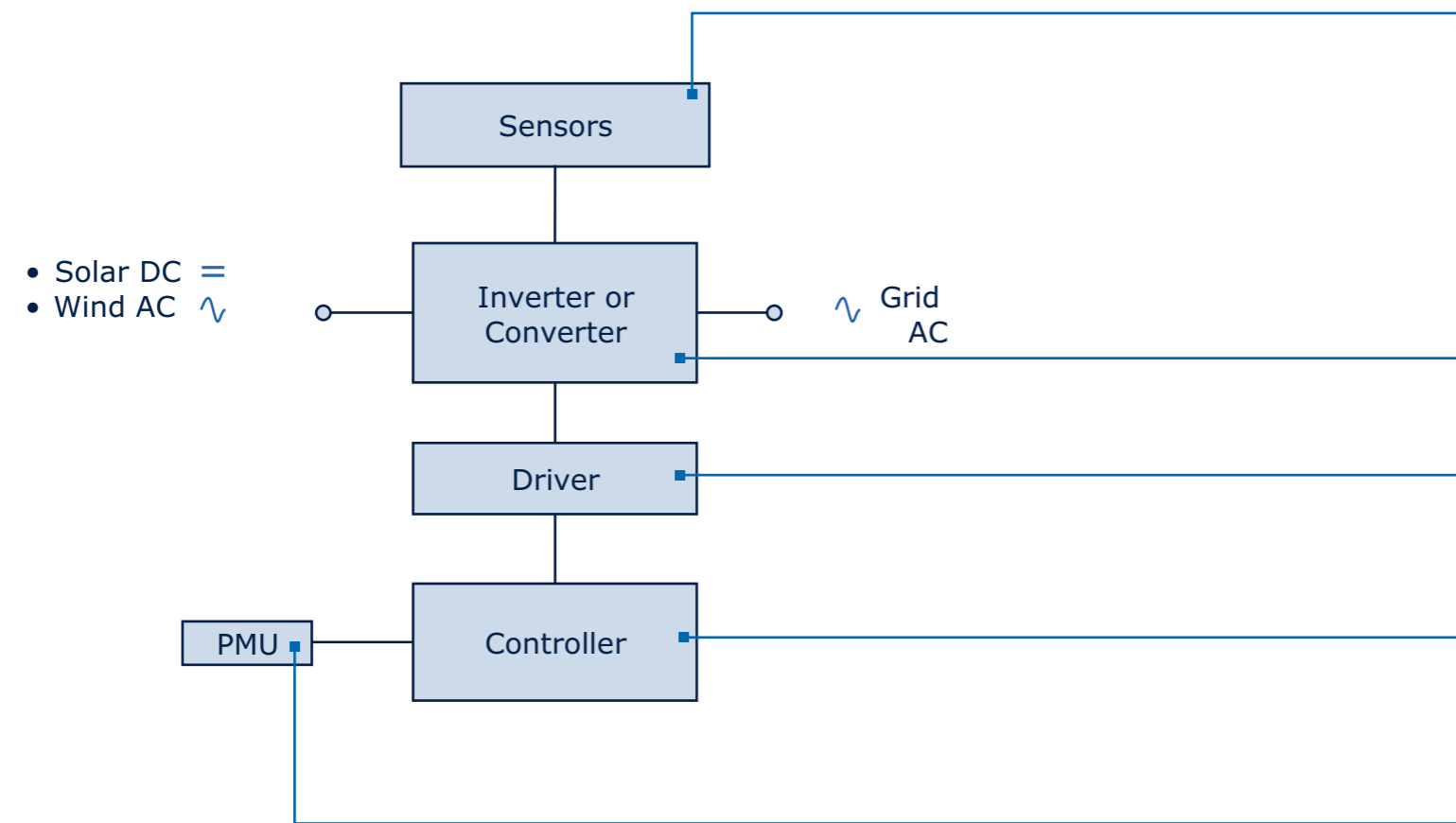

Infineon's Semiconductor Solutions for Integration of Renewable Energy

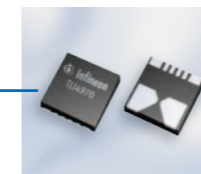

Sensors

Infineon provides linear Hall and Current sensor ICs for renewable energy application designs. Especially its new current sensor for potential-free current sensing within a compact package, provides significant advantages in Power Conversion, transmission and distribution applications such as Solar Inverters, Power Supplies and other applications.



Power Semiconductors

Innovative SiC JFETs, highly reliable thyristor and diode discs, Thyristor & diode Power BLOCK modules/stacks, IGBT modules and a complete set of discrete power semiconductors – meeting the stringent requirements for efficient inverter designs.



SiC Diodes

Infineon's Silicon Carbide Diodes outperform other power diodes with zero reverse recovery charge, benchmark pulse current capability and an unrivalled cost-performance ratio.



Driver ICs

With innovative technologies like thin-film Silicon-On-Insulator and CoreLess Transformer Technology, Infineon's driver ICs achieve higher reliability, lower losses and better performance.



Microcontrollers

Leading-edge real-time performance and dedicated peripheral sets make Infineon's range of 8 to 32-bit microcontrollers the ideal choice for all inverter applications.



Power Management ICs and Voltage Regulators

Infineon's power management IC solutions perfectly harmonize with the requirements and specifications of the driver ICs and microcontrollers for renewable energy applications.

Advanced Transmission and Distribution

A modern transmission system needs adequate and modern electronics.

- Voltage Source Converter High-Voltage DC-Transmission (VSC-HVDC)
- Line Commutated Converter HVDC (LCC-HVDC)
- Ultra High Voltage Direct Current DC-Transmission (UHVDC)
- Flexible AC Transmission Systems (FACTS)

significantly reduce losses in long distance power transmission, enable the integration of more renewable energy and ensure high power quality.

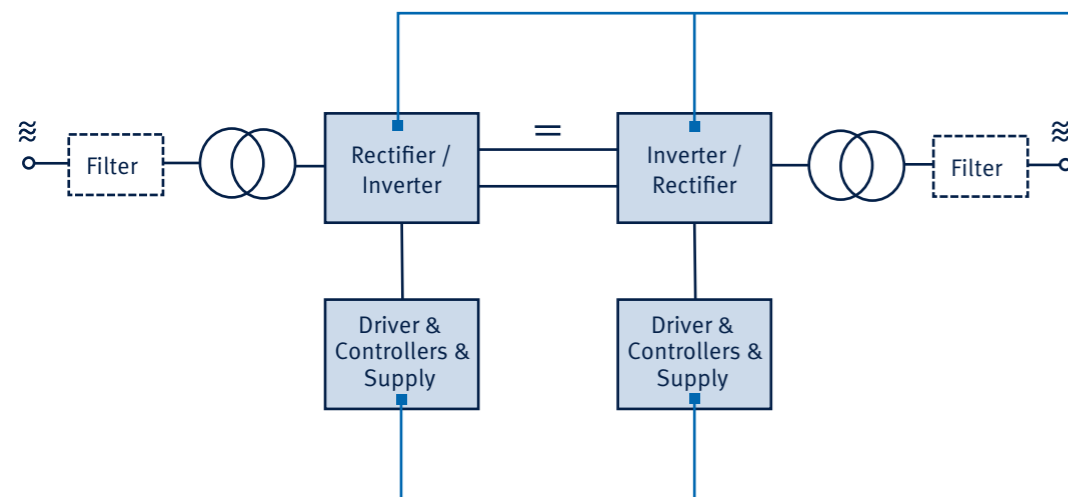

Thyristors have dominated this application for many decades. Nowadays thyristors as well as IGBTs are used in HVDC systems and FACTS to fulfill different needs. Especially grid access systems for offshore wind farms far away from the coast require the turn-off capabilities of IGBTs. Thyristors are targeted at bulk power transmission, such as UHVDC systems with up to 800 kilovolts.

Infineon's Semiconductor Solutions for Advanced Transmission



Thyristor and Diode discs for VSC, HVDC and UHVDC

- Infineon provides a wide range of thyristor and diode discs up to 9.5 kV to be used in HVDC systems and Flexible AC Transmission Systems (FACTS).



IGBTs, IGBT Stacks and Thyristors

- Infineon offers a complete portfolio of high-reliability thyristors, IGBT modules and stacks.



Driver ICs and Microcontrollers

- Infineon's real-time signal controllers combine the strength of a microcontroller unit with the computing power of a digital signal processor – ideal for high-end applications. Driver IC amplifying uC control signal into Power Semiconductor gate drive Power.



Power supply for Driver ICs and Microcontrollers

- Infineon's energy-efficient voltage regulators provide solutions to keep power consumption of the transmission control unit low and requiring only few external components.



Solutions for galvanic isolation and e-metering

- Power transmission and distribution requires reliable and robust isolation as well as precise and secure e-metering. Infineon with its new ISO-ADC as well as its e-metering ICs offers customers highly integrated, custom-made solutions.

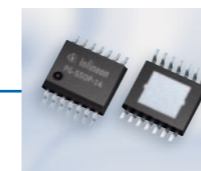

Scalable and efficient solutions for easy SMPS design

- Infineon's wide variety of advanced CoolSET™ SMPS controllers helps to minimize the number of external components by reducing design in time. Infineon offers flexibility to design-in with external power switches.



Smart City

According to the United Nations the population is expected to surpass 9 billion by 2050. By then more than 70% of the population will live in cities.

Urbanization, climate change and demographic change are forcing cities to make their infrastructure more efficient in order to guarantee seamless integration of renewable energies and stable grids and thus maintaining a high quality of life for people living in cities. Infineon's energy-efficient technologies, communication and security products help to master the challenges of urban development now and in the future.



Smart Metering

to balance electricity consumption and available supply by connecting homes to the Smart Grid.

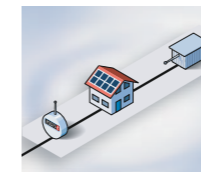

Security

to protect citizen's privacy and to prevent fraud and malicious attacks by cost effective hardware security.



Electric Vehicles

to decrease tailpipe emissions and noise level by driving the power train with increased efficiency.

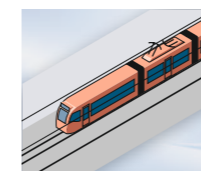

Public Transportation

to better use the energy for mobility by driving vehicles' motors efficiently and by recovering braking energy.



Smart Lighting

to provide energy-efficient, flexible, healthful and safe lighting solutions by progressive, digital and programmable systems and topologies.



Smart Homes

where citizens can easily control, manage and balance energy consumption and generation.



Smart Metering

Advanced metering infrastructure enables demand/load balancing and the implementation of smart homes inside smart grids. Smart meters are the link between the grid and homes: They need to be secure, reliable and cost effective.

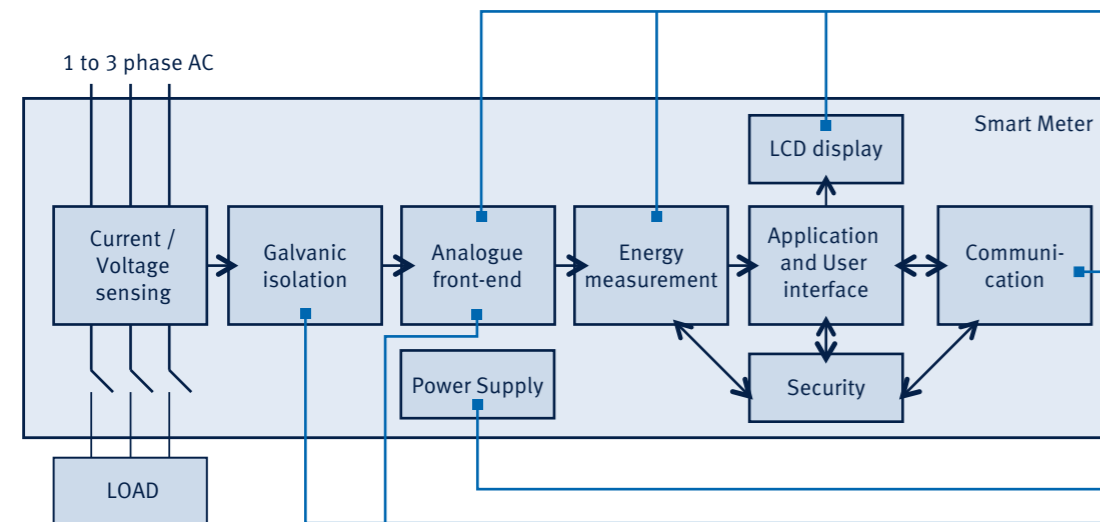

Infineon offers a new class of integrated circuits dedicated to smart metering and home energy control, utilizing Infineon's world class reliable technology and designed to meet customer needs now and in the future. Together with its key customers, Infineon is also active in continuously revising its smart meter and smart home roadmap to anticipate future market needs in our product portfolio.

Infineon's Semiconductor Solutions for Smart Metering



Electric Energy Meter

- Highly integrated and cost-effective ICs based on ARM Cortex, high-endurance Flash memory, a complete energy metrology engine as well as a highly accurate, low-power, temperature-compensated RTC, LCD drivers and a large set of peripherals including a dedicated cryptography engine.



Gas, Water and Heat Meter

- Very low-power, embedded Flash ICs based on ARM Cortex with dedicated flow metering peripherals and direct valve drive. With a highly accurate, low power, temperature-compensated RTC, LCD driver and large set of peripherals including a dedicated cryptography engine.



Sensing and Wireless RF Solutions sub 1 GHz

- Infineon provides a wide set of sensors and low power wireless radios. Uni- and bi-directional communications in the sub 1 GHz range are enabled by Infineon's transceivers which excellently support the Wireless M-Bus protocol, long range reach and low energy consumption combined with highest quality and reliability. Magnetic Hall Switches with low power consumption and accurate pressure sensors allow reliable flow metering.

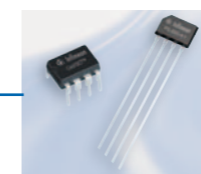

Power Supply

- High temperature range, very efficient and reliable Switched mode power supply can be realized using Infineon's AC/DC controllers, fully integrated CoolSET™ devices and cascoding our best-in-class CoolMOS™ devices to achieve highest breakdown voltage.



Galvanic Isolation

- Tamper-resistant, small form factor and cost-effective solutions for galvanic isolated current and voltage sensing using resistive (ie shunt based) approach thanks to on-silicon galvanic isolated ADC. No power supply on the secondary side is needed as this single-package component embeds also power transfer from the low side power domain.

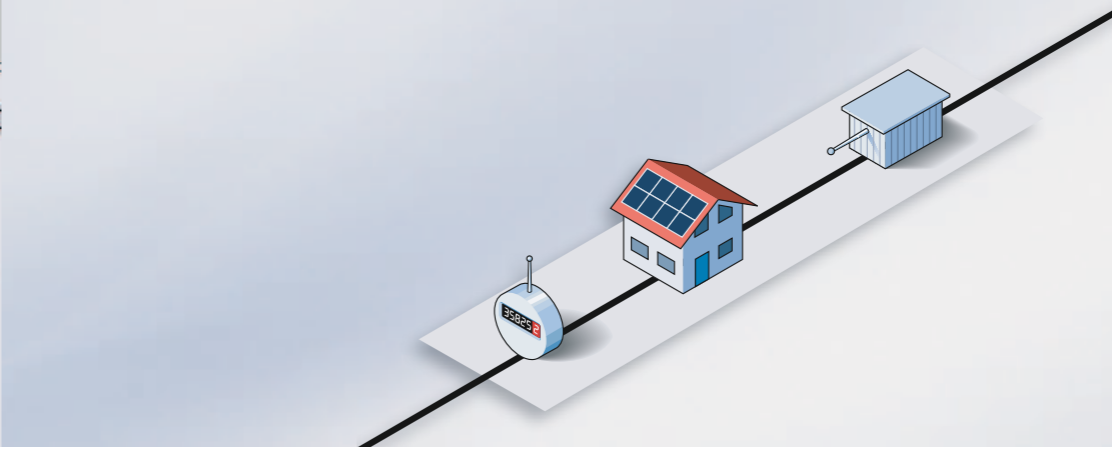

Security

Security in the Smart Grid must be built in from day one. For example the Smart Meters and Gateways installed at the consumer must be protected against manipulation, in order to prevent power theft and to ensure data security. Communication between the appliances concerned must be protected against any infiltration of incorrect data, in the same way as the services for computing energy consumption, billing and invoicing. This also comprises a secure integration of electric vehicles into the Smart Grid. As far as personal data are processed, the appliances and systems developed must consider aspects of data protection, thus preventing e. g. the creation of consumption profiles.

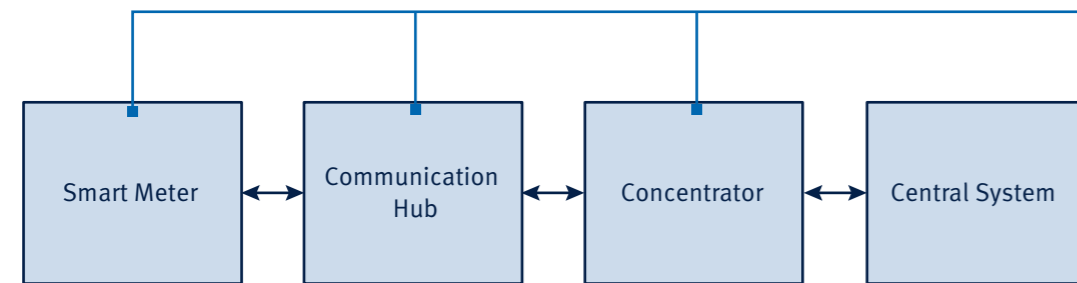

Infineon's security controllers and respective solutions help vendors to provide best-in-class security for their products. Infineon's personalization services provide secure key injection and reduce security expenses in vendors' own manufacturing.

Infineon's security controller and matching solution will be certified according to Common Criteria. This supports best quality and security.

Infineon's Security Controller Solution for Grids and Smart Meters



Security Controller

- Infineon is offering a family of security controllers implementing Integrity Guard, Infineon's new digital security architecture matching the longevity needs of smart meters and concentrators.



Security Solution

- Infineon will offer turnkey firmware executed on the security controller and related APIs for easy integration into devices.



Personalization Services

- The process of injecting keys and secrets into a smart meter must be protected against insider attacks. Infineon is offering personalization services using security-certified manufacturing.



Smart Grid Communication

- The SLS 52EIII000 is the first member of a family of dedicated security controllers for the smart grid. It will be certified according to German „Protection Profile for the Security Module of a Smart Metering System“ that is mandated by the German government for upcoming smart meter gateway installations.



Electric Vehicles

Charging batteries for a rapidly expanding fleet of electric two- and four-wheel vehicles will soon become a major challenge for our grids. However leveraging EV storage may also become a great opportunity to balance demand and supply, thereby increasing the overall asset efficiency.

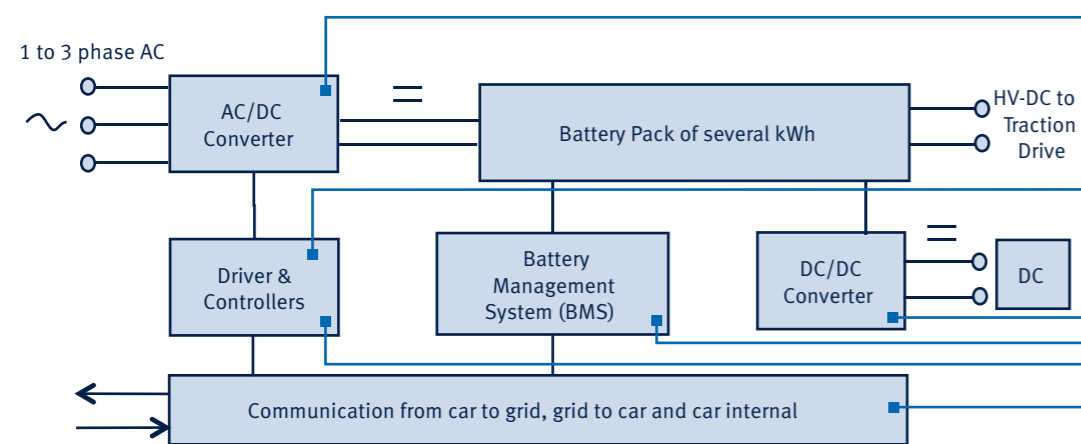

Infineon's power semiconductors like IGBT discrete solutions and modules and CoolMOS™ enable the design of high-power AC/DC, DC/DC and DC/AC converters with efficiencies exceeding 95%. Our complete portfolio provides optimal solutions across the full range of applications, from on-board chargers rated up to a few kW up to MW-rated, high-power chargers in grid-supporting energy storages.

Infineon's Semiconductor Solutions for EV Charging and Energy Storage



CoolSiC™, CoolMOS™ Power MOSFETs and IGBTs

- Infineon offers a complete portfolio of SiC JFETs, IGBTs and power transistors for on-board and off-board charging at the highest efficiency levels as well as for high-power, quick charging stations.



Driver ICs and Power Management ICs

- A wide portfolio of PWM-IC, PFC-IC, Driver IC, linear and switching voltage regulators and System controllers enable an efficient and high power density power supply design.



Battery Management

- Managing batteries in the right way significantly increases their performance, life span and safety – Infineon provides dedicated microcontrollers, power ICs and cell-balancing ICs.



Sensors

- Infineon provides linear Hall and Current sensor ICs for EV charging and energy storage. Where the Current Sensor can directly be used e.g. in stationary or on-board chargers, the linear Hall range of products can be used to build current Sensor Modules e.g. for AD/DC inverters or DC/DC converters.



PLC / CAN-BUS / Wireless RF

- From a simple chip to complete system-level solutions with integrated hardware and software: Infineon offers complete reference platforms and design-in support.



Microcontrollers

- With more than 15 million microcontrollers shipped for use in eBikes, Infineon is offering a proven solution for reliable and cost-efficient system control.

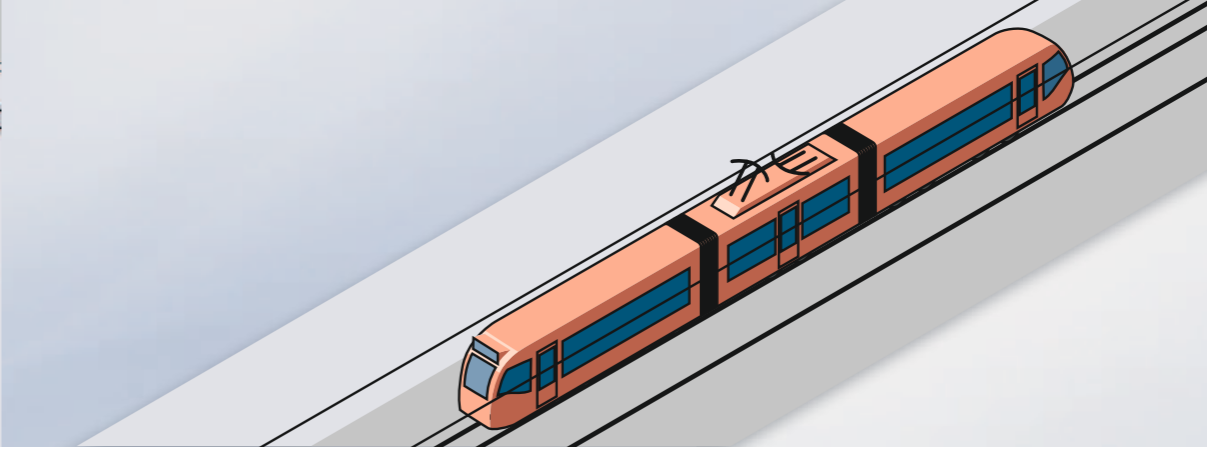

Public Transportation

The wide application area of power semiconductors in locomotives, long-distance trains, metros, trams and hybrid busses and the variety of European and worldwide railroad networks, where you can find many different DC and AC line voltages, require the power electronics manufacturer to provide a wide and optimized product range. Power density and lifetime are the driving forces for the development of new power semiconductors.

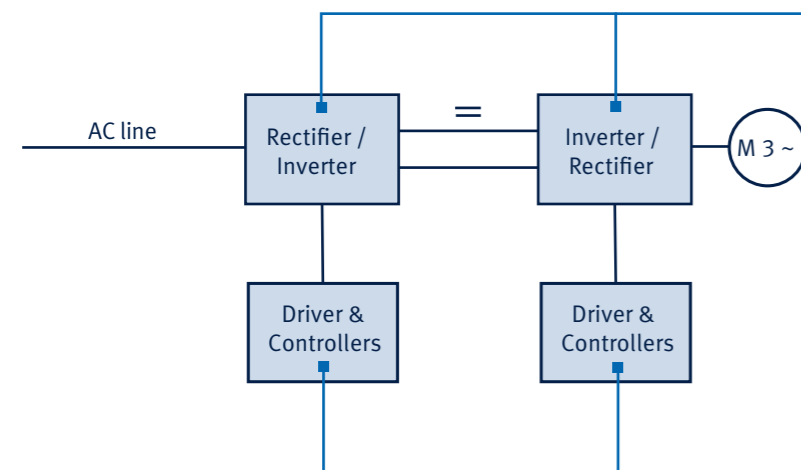

Infineon supplies IGBT modules with voltages of 1200 V to 6500 V and thus offers to its customers an optimal product scope for all possible traction applications worldwide. We realize the different electrical, mechanical and thermal requirements for optimized chip and module technologies, which are continuously improved by us. Doing this, we make sure that new solutions will be compatible with existing ones, so that for the user continued availability over time will be secured.

Infineon's Semiconductor Solutions for Public Transportation



IGBT modules, Thyristors and Diodes

- Infineon offers highly reliable products of highest quality that surpass even the most rigid requirements.

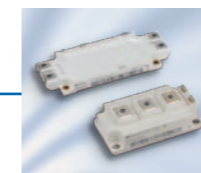

IGBT and Bipolar Modules

- A wide portfolio of innovative components caters to the needs of a variety of traction and auxiliary converters.

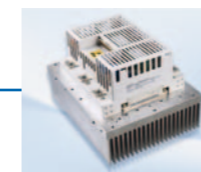

IGBT-Stacks

- The PrimeSTACK™ family is a complete switch solution for power electronic circuits containing all the necessary components for current, voltage and temperature measurements, as are standard features of the Infineon IGBT mass production modules.



Driver ICs and Microcontrollers

- Infineon's real-time signal controllers combine the strength of a microcontroller unit with the computing power of a digital signal processor – ideal for high-end applications. Driver IC amplifies uC control signal into power semiconductor gate drive power.



Power supply for Driver ICs and Microcontrollers

- Infineon's energy-efficient voltage regulators provide solutions to keep power consumption of the transmission control unit low and requiring only few external components.



Smart Lighting

Approximately 20% of the global electrical energy is consumed by lighting applications. The trend towards energy-efficient lighting is apparent and requires both efficient light-source technologies and electronic components. As an example for the same lumen output, an 8.5 W LED bulb replaces a 40 W incandescent bulb. Infineon offers an innovative product portfolio for general lighting applications, supporting benchmark efficiency improvement, system miniaturization, reliability and overall cost savings.

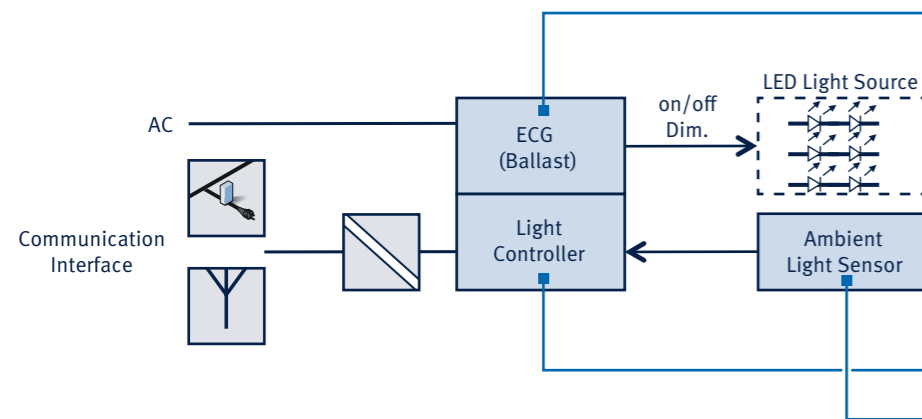

Infineon delivers innovative, high-performance solutions with best-in-class technologies that can be used in residential, commercial, industrial and outdoor lighting applications.

Infineon's Semiconductor Solutions for Lighting

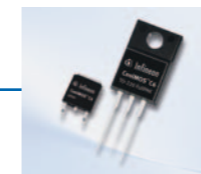

Power MOSFETs

- Infineon offers a comprehensive portfolio of High Voltage and Low Voltage MOSFETs for lighting applications.



Lighting ICs, LED Drivers & Power Management ICs

- Infineon delivers dedicated and optimized IC products that can be used in a broad range of applications from LED retrofit to complex commercial lighting systems.



Microcontrollers and Power Supply

- Low pin-count X82x and XC83x microcontrollers for touch control and LED displays, as well as for dimming of LED strings and DALI control. Supplied by highly efficient Infineon voltage regulators.



Ambient Light Sensor

- Ambient light photodiode with sensitivity characteristic close to the human eye and 16 bit resolution with I²C interface for ambient light sensing. Enables significant energy savings by exactly providing the right illumination.

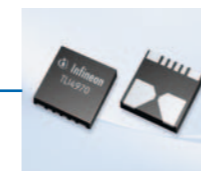

Current Sensors

- Infineon provides current sensor ICs for various public lighting solutions. Especially our new current sensor for potential-free current sensing within a compact package, provides significant advantages in illuminated (outdoor) advertising and LED lighting solutions (public and corporate).

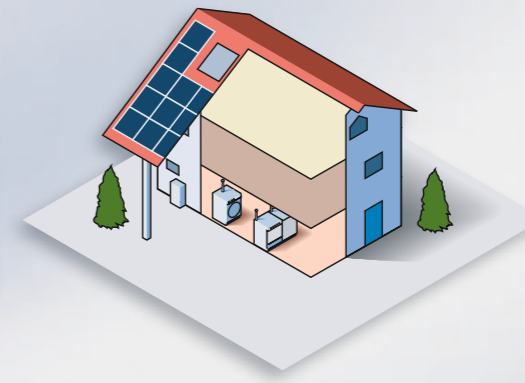

Smart Homes

Reduction of carbon emissions and of energy footprint is not only a matter of efficient generation and transmission, it is rather a duty on every citizen to minimize and manage the consumption in every home. Infineon offers a wide range of products enabling an easy, reliable and cost-effective implementation of smart homes: from smart grid communication to smart metering to home area networks to intelligent appliances and smart plugs, to „zero standby power“ digital power supply solutions.

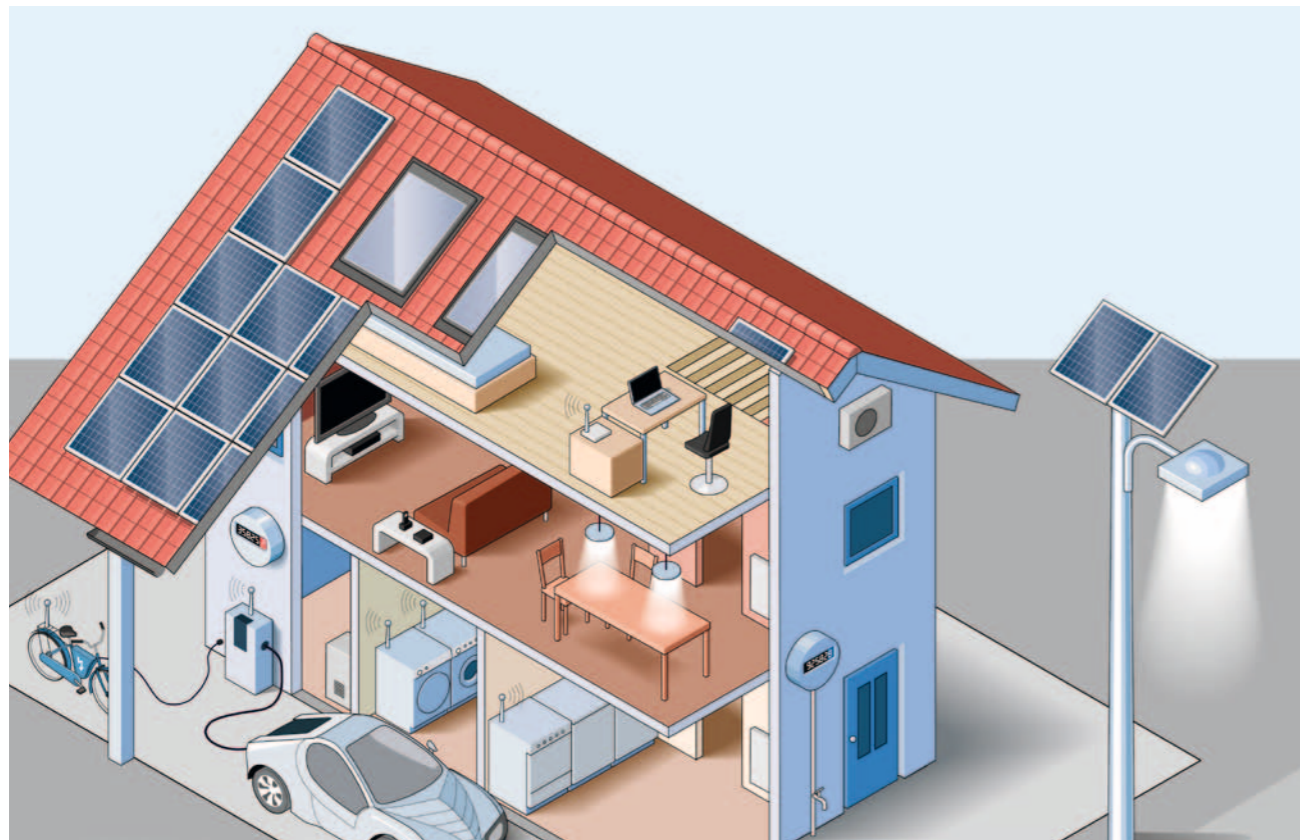

Infineon's Semiconductor Solutions for Smart Homes



Home Energy Management

- Infineon offers dedicated ICs for establishing a wireless home area network for smart homes.



Smart Appliances

- Best-in-class ICs for smart home appliances connected to the grid to offer safe communication and effective energy/load management via its galvanic isolated ADC, energy meter MCUs and efficient motor drives.



Smart Plugs

- As a market leader in power management products, Infineon offers a vast portfolio of power semiconductors for efficient power switches and highly integrated energy measurement and communication solutions.

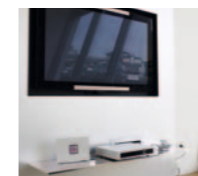

Efficient Consumption

- Infineon offers highest efficient solutions by targeting 0 standby power mode for lighting, computing and many other home appliances.



Renewable Integration

- With Infineon's discrete devices, power modules and diodes, the robust and reliable integration from smart home to the grid is safely enabled.



Sensors

- Infineon provides linear hall and current sensor ICs where the sensors can be directly used in power conversion applications as well as current management and monitoring devices in smart home networks.

Ask Infineon. Get connected with the answers.

Where you need it. When you need it.

Infineon offers its toll-free 0800/4001 service hotline as one central number, available 24/7 in English, Mandarin and German.

Our global connection service goes way beyond standard switchboard services by offering qualified support on the phone. Call us!

- Germany 0800 951 951 951 (German/English)
- China, mainland 4001 200 951 (Mandarin/English)
- India 000 800 4402 951 (English)
- USA 1-866 951 9519 (English/German)
- Other countries 00* 800 951 951 951 (English/German)
- Direct access +49 89 234-0 (interconnection fee, German/English)

* Please note: Some countries may require you to dial a code other than "00" to access this international number, please visit www.infineon.com/service for your country!

Where to Buy

Infineon Distribution Partners and Sales Offices

Please use our location finder to get in contact with your nearest Infineon distributor or sales office.

www.infineon.com/WhereToBuy

Infineon Technologies – innovative semiconductor solutions for energy efficiency, mobility and security.



Published by
Infineon Technologies AG
85579 Neubiberg, Germany

© 2012 Infineon Technologies AG.
All Rights Reserved.

Visit us:
www.infineon.com

Order Number: B192-H9433-G2-X-7600
Date: 09 / 2012

ATTENTION PLEASE!

The information given in this document shall in no event be regarded as a guarantee of conditions or characteristics ("Beschaffheitsgarantie"). With respect to any examples or hints given herein, any typical values stated herein and/or any information regarding the application of the device, Infineon Technologies hereby disclaims any and all warranties and liabilities of any kind, including without limitation warranties of non-infringement of intellectual property rights of any third party.

INFORMATION

For further information on technology, delivery terms and conditions and prices please contact your nearest Infineon Technologies Office (www.infineon.com).

WARNINGS

Due to technical requirements components may contain dangerous substances. For information on the types in question please contact your nearest Infineon Technologies Office. Infineon Technologies Components may only be used in life-support devices or systems with the express written approval of Infineon Technologies, if a failure of such components can reasonably be expected to cause the failure of that life-support device or system, or to affect the safety or effectiveness of that device or system. Life support devices or systems are intended to be implanted in the human body, or to support and/or maintain and sustain and/or protect human life. If they fail, it is reasonable to assume that the health of the user or other persons may be endangered.